

RDU dual balanced seal

COMPACT CARTRIDGE SEAL FAMILY

Description

Type RDU is a very compact cartridge dual balanced mechanical seal designed to seal a wide range of hazardous and/or chemically aggressive fluids, and fluids with solids.

RDU seals show best performance at:

- Liquor pumps at pulp and paper industry
- Stock pumps at pulp and paper industry
- Chemical pumps at various industries
- Water with abrasive particles pumps

Materials	
Seal faces	Self-sintered silicon carbide, tungsten carbide, carbon graphite, Trembide 85, Trembide 50
Secondary seals	EPDM, fluoroelastomer, perfluoroelastomer, and others
Springs	Hastelloy® C
Metal parts	SS316, SS304, SS3214, Titan, and others

Technical data	
Temperature	From -40 up to +260 °C
Dynamic Pressure	Up to 25 bar
Static pressure	Up to 60 bar
Speed	Up to 25 m/s

Recommended API Plans for RDU seals			
API Plan (per API 682)	Description	Application guidelines	Auxiliary units
52	Non-pressurized external fluid reservoir with forced circulation	Most of light and heavy hydrocarbons, alcohols, solvents, etc	Barrier fluid tank SO-3, with ball valves and instrumentation
53	Pressurized external fluid reservoir with forced circulation	Fluids with high content of mechanical impurities, hazardous fluids, crystallizing fluids	
54	Circulation of clean fluid from external system	Fluids with solids, crystallizing fluids, liquors.	-

All of the above systems can be supplied with:

- level sensors/indicators
- pressure switch
- temperature sensor
- safety valve
- ball valves
- and other C&I devices and valves

Advantages

- Type RDU cartridge dual mechanical seal has a compact but sturdy design. Good performance, long MTBF, and safety are ensured by:
 - self aligning stationary seal rings to compensate for seal chamber face runout;
 - extended axial shaft movement compensation capability;
 - finite element analysis optimized seal rings to minimize deformation and emissions.
- Springs are made of Hastelloy® C to prevent corrosion cracking.
- Special alloys are available to make metal parts to resist corrosion.
- Being a very compact seal, type RDU can be used on most pumps, mixers and other equipment with limited space seal chambers.
- Special design sleeve is available to protect shaft from corrosion (pumps series EPP and APP).



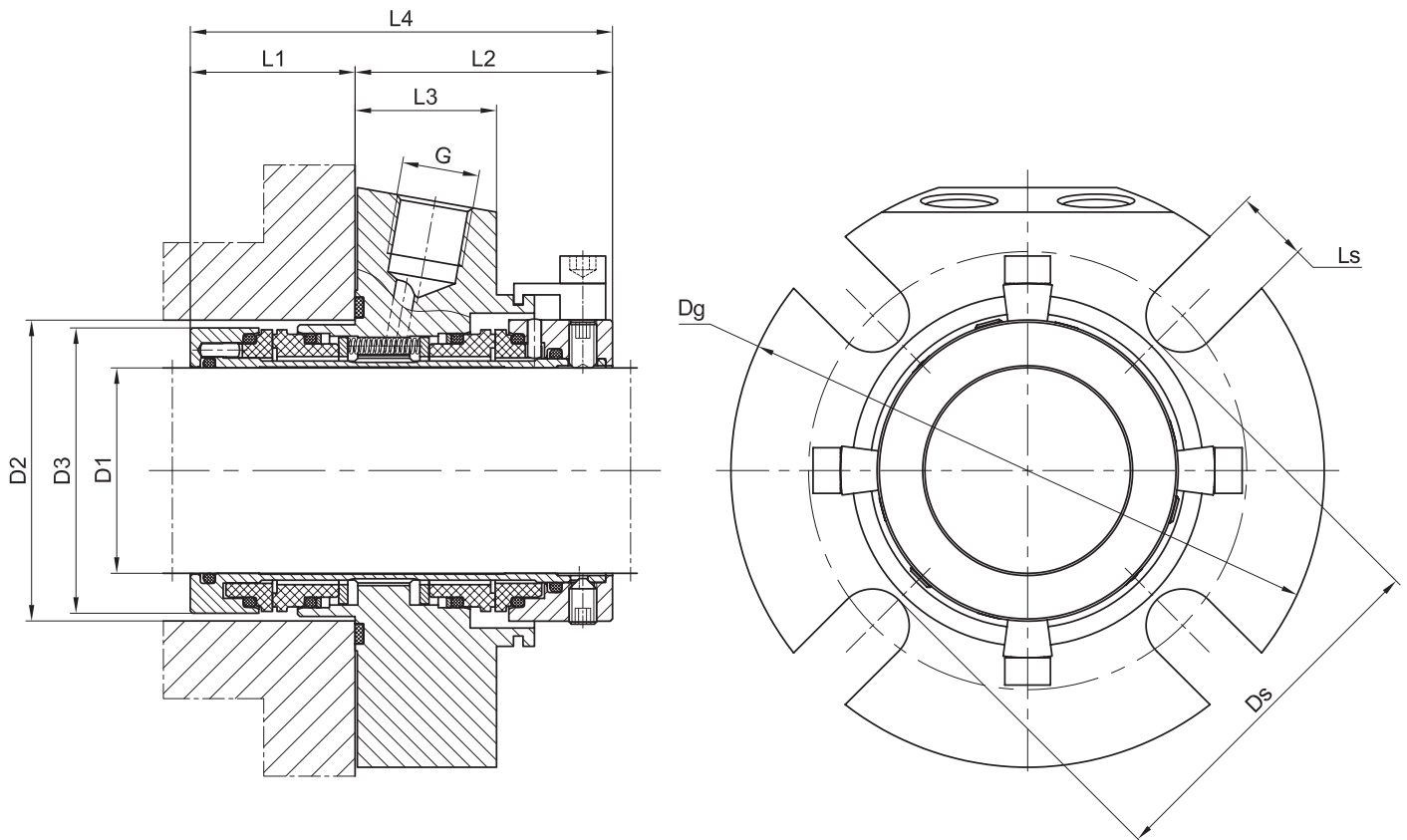

D1	D2min	D2max	D3	Dg	Ds	L1	L2	L3	L4	Ls	G
22	40	48	38	105	56	36,1	56,4	31	92,5	14	1/4
25	44	51	43	105	58	36,1	56,4	31	92,5	14	1/4
26	44	51	43	105	58	36,1	56,4	31	92,5	14	1/4
28	47	52	46	105	58	36,1	56,4	31	92,5	14	1/4
30	49	56	48	105	65	36,1	56,4	31	92,5	14	1/4
32	51	57	49,8	105	65	36,1	56,4	31	92,5	14	1/4
33	51	57	49,8	110	67	36,1	56,4	31	92,5	14	1/4
35	54	62	53	113	67	36,1	56,4	31	92,5	14	3/8
38	57	66	56	123	70	36,1	56,4	31	92,5	14	3/8
40	59	69	58	123	75	36,1	56,4	31	92,5	16	3/8
43	61,5	70,5	60,5	130	80	36,1	56,4	31	92,5	16	3/8
45	64	73	62,5	130	80	36,1	56,4	31	92,5	16	3/8
48	67	75	65,6	138	84	36,1	56,4	31	92,5	16	3/8
50	69	78	68	142	87	36,1	56,4	31	92,5	16	3/8
53	73	87	72	147	97	36,1	56,4	31	92,5	18	3/8
55	74	83	73	147	97	36,1	56,4	31	92,5	18	3/8
60	79	91	78	157	102	36,1	56,4	31	92,5	18	3/8
65	84,5	99	83	163	109	36,1	56,4	31	92,5	18	3/8
70	95	108	93	170	118	46	67,5	35	113,5	18	3/8
75	100	119	98	190	129	46	67,5	35	113,5	18	3/8
80	107	124	105	195	135	46	67,5	35	113,5	18	3/8
85	112	128	110	200	139	46	67,5	35	113,5	22	3/8
90	117	135	115	205	145	46	67,5	35	113,5	22	3/8
95	120,7	137	119	210	148	46	67,5	35	113,5	22	3/8
100	127	144	125,4	218	154	46	67,5	35	113,5	22	3/8